



Quest Rugged Industrial Tablet



The Quest Rugged Tablet delivers strong performance, reliable connectivity, and durable construction for a variety of demanding environments. Powered by Intel® Core i5 or i7 processors with 16GB of memory and up to 512GB of storage, it runs Windows applications smoothly in demanding conditions. Its 10.1" IPS display provides clear visibility indoors or outdoors, and built-in WiFi 6, Bluetooth 5.1, optional 4G, and a full range of ports keep teams connected. With IP65 protection and optional accessories like a docking charger, hand strap, and vehicle mount, the Quest is built to handle every job with confidence.

Discover the Touch Dynamic Difference.

DESIGNED AS AN IDEAL SOLUTION FOR:



Manufacturing



Retail



Field Service



Healthcare



AND MORE!

KEY FEATURES & BENEFITS

Reliable Performance

- ★ Intel® Core i5 or i7 CPU
- ★ 16GB Memory / Up to 256GB SSD Storage
- ★ Supports GPS, BDS, and GLONASS Navigation

Custom Configuration

- ★ Vast Accessory Options
- ★ Choose From 4 Modules: Ethernet, DB9, USB 2.0 or 2D Scanner Module

CONTACT US



Quest Rugged

Industrial Tablet



Product Specifications

CPU / Processor	Intel® Core i5-1235U Intel® Core i7-1255U
Memory	16GB
Storage	128GB / 256GB (up to 512GB)
Supported OS	Windows 11, Windows 10
I/O Ports	1 x USB-A 3.0 1 x USB-C 1 x HDMI 1.4a 1 x SIM Card 1 x TF Card 1 x 12-Pin Pogo Connector 1 x Audio Jack 1 x DC Jack
Wireless Connectivity	Wi-Fi 6 & BlueTooth Built-in GPS, GLONASS, Optional BDS Optional 4G/LTE
Power	65W / 19V
Display	10.1" True-Flat PCAP Multi-Touch (1920 x 1080)
Camera	2.0 MP Front Camera 8.0 MP Rear Camera
Peripheral (options)	Additional Module: RJ-45 LAN port, DB9 Serial port, USB 2.0, or 2D Scanner Module Docking Charger Hand Strap Vehicle Mount Car Charger Carry Handle
Reliability	IP65 Certified, MIL-STD-810G Certified
Environment	Operating Temp: 4°F to 140°F (-20°C to 60°C) Storage Temp: -22°F to 158°F (-30°C to 70°C) Humidity: 95% non-condensing
Dimensions	11.4" W x 7.7" H x 1.1" D 2.5 lbs

Default Configurations

Product Code	Description
QR250LW2-NNNNNNN	10" Rugged Tablet, Intel Celeron N5105 CPU, 16GB RAM, 128GB EMMC, HandStrap, Windows 11 IOT, 2D Scanner

Quest Rugged Tablet Drawings

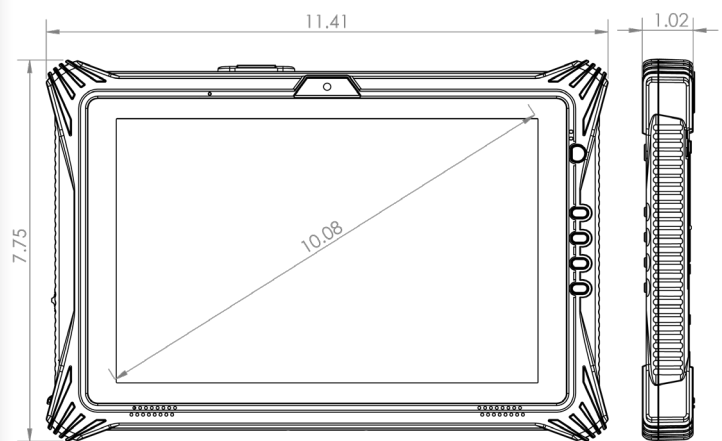

Product specifications and data are subject to change without notice.

CONTACT US

